

Model S100

General Purpose Scale



- **Accuracy**– 0.01% of full scale
- **Capacity**– 150 lb (75 kg), 300 lb (150 kg) and 600 lb (300 kg)
- **Construction**– Stainless steel weight platter, painted mild steel base, ABS indicator
- **Display**– Large, easy to read, bright red LED display
- **Power**– AC/Mains power and built-in rechargeable lead-acid battery
- **Operator Keys**– Power/Zero, Tare, Units, Hold/Print
- **Platform Length**– 18" x 22" (457 mm x 559 mm)
- **RS-232**– Standard

VALUE IN
WEIGHING

S100 General Purpose Scale

Features

The S100 is a low cost general purpose, self-contained industrial scale with RS-232 interface for simple non-trade weighing applications.

Column or Desk Mount Indicator– Attach the indicator to the stainless steel column to provide a total height of 36.5" (927 mm) or remote the indicator up to 48" (1220 mm) without the use of column

RS-232 Interface– SBI 100 indicator can be configured for weight only or GTN via continuous output, print key, or stable weight. Choose bi-directional interface for communication to a PC

ON/OFF Switch– Remove power from indicator to increase battery performance and life of product

Auto Shut-off Timer– Adjustable from 1-15 minutes or Off

Weight Hold Functions– Can be configurable for manual button release, automatic release on change in weight, or within +/- 3-50 scale divisions

Internal Rechargeable Battery– Low battery and battery charging annunciators indicate status of lead-acid battery. Battery is charged while AC power is active.

Units Switching– Can be configured for LB/KG switching, LB only, or KG only

Adjustable Resolution Setting– Factory default setting of 6,000 or 7,500 divisions can be modified to increase performance within certain applications

Adjustable Scale Setting– Power on zero, AZT, 4 filter settings, weight stability, overload, baud rate and status bits

Robust Design– Re-enforced painted mild steel base, stainless steel weight platter and pole, robust ABS plastic indicator with strain relief connections, and heavy duty adjustable foot assemblies

Specifications

Capacity– 150 lb x 0.02 lb (75 kg x 0.01 kg)
300 lb x 0.05 lb (150 kg x 0.02 kg)
600 lb x 0.1 lb (300 kg x 0.05 kg)
The Model S100 is non-trade approved

Construction– Mild steel base, stainless steel top cover and display pole, ABS plastic indicator

Tare– 100% subtractive

Display– Six digit 0.8" (20 mm) high red LED display with 8 separate LED annunciators

Annunciators– Net, zero, kg, lb, hold, low battery, battery charging, mains connected

RS-232– Standard 9 pin straight pass through interface connector, interface cable not included

Function Keys– Power Switch, On/Off/Zero, Tare, Units, Hold/Print

Auto-off– Selectable between 1 to 15 minutes after inactivity

Power–

North America: 120V AC @ 60Hz, 12 VDC, 500mA UL Approved wall mount power adapters

UK/EU: Version Power Supply 230V @ 50 Hz 12 VDC, 500mA, CE approved 3 pin UK and 2 pin EU 230V wall mount power adapters

AUS/SA: Version Power Supply 100-240V @ 50/60Hz, 12 VDC, 500mA, C-tick approved 3 pin Australian and a 3 pin South African wall mount power adapters

Battery Life– Up-to 35 hours of continuous use

Operating Temp– 41° F to 95° F (5° C to 35° C)

Weight– 44 lb (20 kg)

Packaging Dimensions– 35" L x 24" W x 8" H
965 mm (L) x 610 mm (W) x 203 mm (H)

Shipping Weight– 53 lb (24 kg)

Packaging Contents– SBI 100 indicator, S100 base with load cell interface cable, power supply(s), SS mounting pole, indicator mounting hardware.

Approvals– Full FCC compliance, UL/CUL power adapter, CE, WEEE directive

Dimensions

A = 22" (559 mm)
B = 18" (457 mm)
C = 5" (127 mm)

Indicator

D = 9.75" (248 mm)
E = 5.5" (140 mm)
F = 5.75" (140 mm)
G = 36.5" (927 mm)

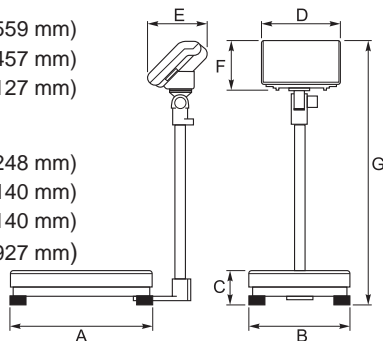

a division of Avery Weigh-Tronix, LLC

Salter Brecknell Weighing Products

1000 Armstrong Dr., Fairmont, MN 56031
Toll free: 800-637-0529, Tel: 507-238-8702
Fax: 507-238-8271
e-mail: sales@salterbrecknell.com
www.salterbrecknell.com

