



# Defender™ 5000

Square Scales



## **Smart Functionality, Durability, OHAUS Quality and Value**

The OHAUS Defender™ 5000 Series is a feature-rich line of bench scales, combining an ABS plastic T51P indicator with square, painted steel base and column. Ideal for shipping and receiving, production, packaging and general commercial and industrial weighing applications, the Defender 5000 offers a multifunctional indicator with multiple weighing units and software modes to meet the requirements of industrial and lab applications. With rugged construction, comprehensive yet intuitive software and multiple connectivity options, the Defender 5000 can meet the needs of demanding industrial operations.

### **Standard Features Include:**

- Painted steel base with ABS indicator
- 10,000-12,500d default resolution
- Quick display of results using large LCD with high-contrast white backlight
- Temporary display of 10x readability in weighing mode using quick key press
- Easy to operate with 4-key membrane keypad with raised tactile keys
- Weighs in one or more units: kg, g, lb, oz, lb:oz (decimal), tonnes and user-definable custom unit
- Multiple weighing modes including Counting, Percent Weighing, Dynamic/Animal Weighing, Checkweighing, and Display Hold
- Internal power supply with universal line cord or 6 "C" batteries (80 hour battery life) – optional NiMH internal rechargeable power pack available
- Includes RS232 interface with GMP/GLP data output including date and time
- Base and indicator connected using quick connect plug
- Optional interfaces include DC relay control kit, AC relay control kit, 2nd RS232 and RS485/422

# Defender™ 5000 Square Scales

## The Defender 5000 Offers Multiple Features and Easy Configuration:

To meet different operational needs, the Defender 5000 includes a suite of configurable software:

- Counting mode for packaging and inventory control, enabling counting into a container or out of a container for bulk operations. Supports a maximum counting resolution to 1:300,000 (minimum APW equal to 0.1d), selectable auto-optimization of average piece weight (APW). APW data can be displayed at any time using a quick key press.
- Percent Weighing mode for formulation and mixing applications, with display of reference weight with quick key press.
- Dynamic/Animal Weighing with selectable weigh times from 0-60 seconds
- Checkweighing function for packaging and weight checking, with display of results using LCD display and red/yellow/green LEDs. Audible beeper can be configured to prompt when weight is within range, under, over, or under or over range. Target weight values can be displayed at any time using a quick key press.
- Display Hold mode for weighing large packages holds last stable weight on display until cleared
- The Defender 5000 weighs in one or more user-selectable units: kg, g, lb, oz, lb:oz (decimal), tonnes and user-definable custom unit
- Supports GMP/GLP data output with date, time user ID, project ID and scale ID. The Defender 5000 features selectable print options for data and print format
- To limit operator access to functions, the Defender 5000 offers both software lockouts for menu items as well as individual key functions.

### Outline Dimensions

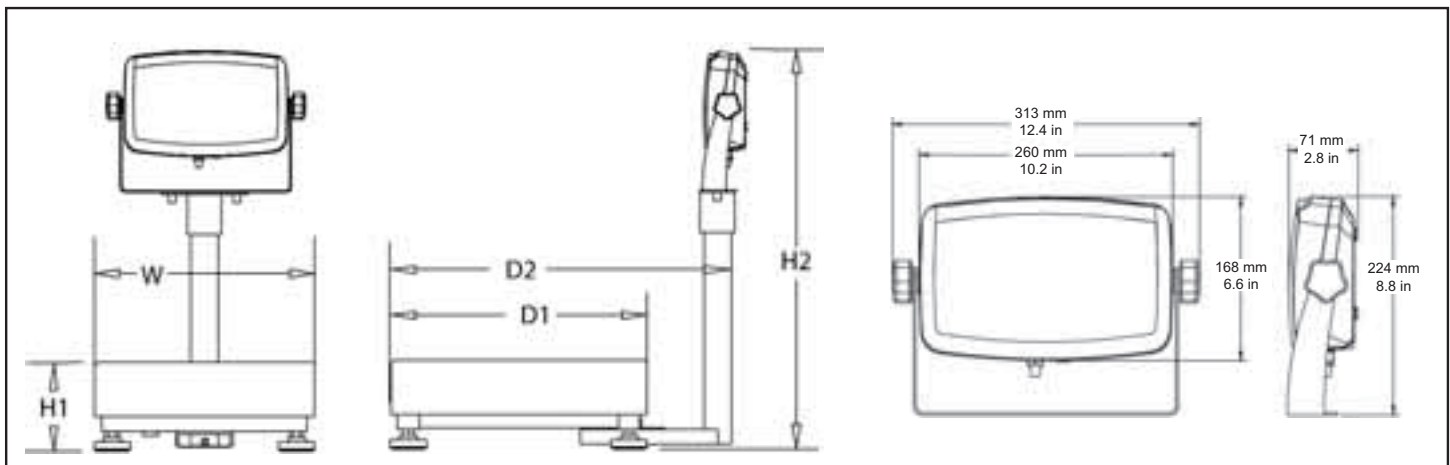

## Standard Features:

**High-Visibility LCD Display**  
with bright white LED back-light and fast display stable weight within 2 seconds

**Internal Slot for Capacity Label**  
Protects label from the effects of moisture and external environments

**Reversible Rear Housing**  
Cables can exit above (table or front scale mounting) or below (wall or bench scale mounting) for convenient mounting. Front scale mounting with available accessory. Internal structural ribs provide strength and minimize flexing.

**3-Color LED Checkweigh Indication**  
with configurable beeper alert

**Simple Plug-In Battery Installation**  
Use six C- alkaline batteries or the optional NiMH battery

**Included Table/Wall Mount Bracket**  
With large ergonomic adjustable knobs to maximize viewing angles. A ratchet-type angle adjustment with metal inserts ensure that viewing angles are set securely, and lasts a long time even with frequent adjustments

**One-Key, Multiple Mode Selection**  
Counting, Dynamic Weighing, Display Hold, Percent Weighing and Checkweighing

**Stay Connected**  
Built in RS232 bi-directional interface and external input, optional RS422/485, optional second RS232 and optional AC or DC relay

**Universal Switching Power Supply**  
100-240 VAC with AC line cord; no need for an external AC adapter!

**Plug-in Load Cell Connector**  
Allows for simple connection to Defender bases or directly to terminal block.

**Painted Steel Columns**  
Available in both short and tall lengths

**Fully Adjustable Feet**  
Four rugged, adjustable feet help prevent slippage on wet or uneven surfaces

**Durable Base Frame Construction**  
Stainless steel pans and painted steel form-and-weld frames (R, L bases) provide maximum durability, rigidity and structural integrity. Load-unload cycle tested to ensure long-term performance.

### Options and Accessories

#### Interface Options

	OHAUS Number
AC Relay Kit .....	80500720
DC Relay Kit .....	80500727
RS485/422 Interface Kit .....	80500731
Second RS232 Interface Kit.....	80500733
Foot Switch .....	71173378

#### Power Options

Rechargeable Battery Kit, T51P/T51XW.....	80500729
---	----------

#### Other Accessories

RS232 Cable to SF42 Printer .....	80500571
RS232 Cable to PC 25-pin .....	80500524
RS232 Cable to PC 9-pin .....	80500525
Compact Impact Printer, 42 Column .....	SF42
Paper for SF42 printer (5 pack) .....	12101511
Ribbon for SF42 printer .....	12101512

# Defender™ 5000 Square Scales

## Specifications

Model	D51P10QR1	D51P25QR1	D51P50QL2	D51P100QL2	D51P250QX2
Capacity (max) x Default Readability (d)	25lb x 0.002lb 400oz x 0.05oz 25lb : 0.05oz 10kg x 0.001kg 10000g x 1g	50lb x 0.005lb 800oz x 0.1oz 50lb x 0.1oz 25kg x 0.002kg 25000g x 2g	100lb x 0.01lb 1600oz x 0.2oz 160lb : 0.2oz 50kg x 0.005kg 50000g x 5g	250lb x 0.02lb 4000oz x .5oz 250lb : .5oz 100kg x 0.01kg 100000g x 10g	500lb x 0.05lb 8000oz x 1oz 500lb : 1oz 250kg x 0.02kg 250000g x 20g
Maximum Displayed Resolution	1:12500	1:12500	1:10000	1:12500	1:12500
Indicator Model	T51P				
Column	13.8 in / 350 mm painted steel		26.8 in / 680 mm painted steel		
Construction	ABS plastic indicator, stainless steel removable weighing platform, painted steel column and base construction, aluminum loadcell				
Safe Overload Capacity	150% of maximum capacity				
Protection	Dry use for scale, IP67 for loadcell				
Weighing Units	lb, oz, lb:oz, kg, g, custom unit				
Modes	Static Weighing, Dynamic Weighing, Counting, Checkweighing, Percent Weighing, Display Hold				
Display	1 in / 25mm high 6-digit, 7-segment bright white backlit LCD				
Keyboard	4-button membrane switch				
Stabilization Time	Within 2 seconds				
Auto-zero Tracking	Off, 0.5, 1 or 3 d				
Zeroing Range	2% or 100% of capacity				
Calibration	Span: 1kg or 1lb to 100% of capacity / 3-point linearity (0 - 50% - 100% fixed)				
Power	100-240 VAC / 50-60Hz internal universal power supply, 6 'C' cell batteries (not supplied) with 80 hour life				
Interface	RS232 and external input				
Operating Temperature Range	14°F to 104°F / -10°C to 40°C				
Shipping Dimensions (L x W x H)	19.3 x 16.1 x 17.3 in 490 x 410 x 440 mm		31.2 x 23.6 x 9.5 in 810 x 600 x 240 mm		39.4 x 29.9 x 9.8 in 1000 x 760 x 250 mm
Scale Dimensions (W x H1 x H2 x D1 x D2)	12 x 3.7 x 23.2 x 12 x 16.7 in 305 x 95 x 590 x 305 x 425 mm		18 x 4.5 x 37 x 18 x 22.7 in 457 x 115 x 940 x 457 x 577 mm		24 x 5.4 x 37 x 24 x 28.7 in 610 x 137 x 940 x 610 x 730 mm
Net Weight	32.4 lb / 14.7 kg		66.6 lb / 30.2 kg		83.8 lb / 38.0 kg
Shipping Weight	37.7 lb / 17.1 kg		71.4 lb / 32.4 kg		97.9 lb / 44.4 kg

## Features

**T51P:** ABS plastic housing with internal rib reinforcements, reversible rear cover, backlit LCD weight display, checkweighing indication (green, yellow, red), membrane keypad with raised tactile keys, built-in bi-directional RS232 with manual/continuous/interval printing, external tare input, hardware configuration lockout switch, internal switching power supply with line cord and battery power using 6 "C" cell batteries.

## Other Features

Zero point calibration, calibration test, span or linear calibration, selectable auto-zero tracking range, selectable stability range, selectable averaging level, selectable LCD backlight, selectable auto shutoff, retain zero weight data after power-off, Geo gravity adjustment, selectable key beep, key function lock, menu lock, selectable power-on and calibration unit, battery status display, display of gross/net weight, indication of stability, center of zero, over- and underweight, overload and underload conditions. Configuration menus for PRINT1, PRINT2, COM1, COM2, and I/O.

## Compliance

- **Safety and EMC:** cUL<sub>US</sub> 2005/95/EC low voltage directive: EN60950-1:2001, FCC Part 15 Class A 2004/108/EC EMC directive: EN61326-1:1997; +A1:1998; +A2:2001; + A3>2003
- **Other:** Compliant to Directive 2002/96/EC on waste electrical and electronic equipment (WEEE)
- **Quality:** Ohaus quality management system registered to ISO 9001:2000

## OHAUS CORPORATION

\* 19A Chapin Road  
P.O. Box 2033  
Pine Brook, NJ 07058 USA

Tel: 800.672.7722  
973.377.9000  
Fax: 973.593.0359

www.ohaus.com

With offices throughout Europe,  
Asia, and Latin America

## \* ISO 9001

Registered Quality Management System

80774411 © Copyright Ohaus Corporation

