

MSI-5300 Load Ranger Specifications

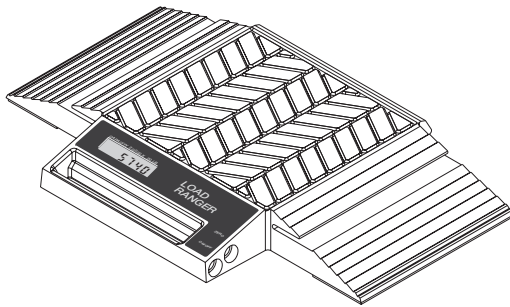
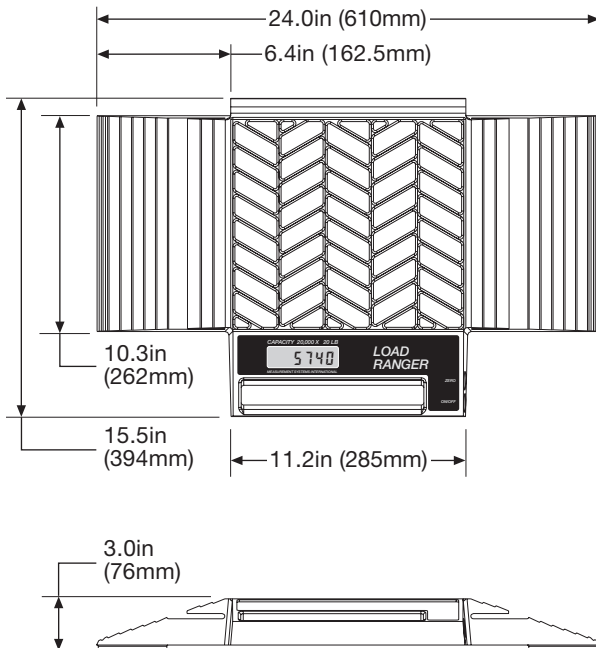

- Accuracy: 1.0% Approved to NTEP, Class III Standard
- Capacity: 20,000 lb (10,000kg) per pad
- Resolution: 20 lb (10kg), 50 lb (20kg) - NTEP
- Power: 6 volt rechargeable (40 hours between charging)
- Battery Charger: 115/230 VAC External, 12 VDC External
- Display: 5 digit, 0.8in (20mm) Liquid Crystal
- Annunciators: Low Battery
- Operating Temperatures: -25° to 140°F (-32° to 60°C)
- Safe Overload: 150% of capacity
- Ultimate Overload: 200% of capacity
- Overall Weigh Pad Dimensions: 24.0in x 15.5in x 3.0in (610mm x 394mm x 76mm)
- Enclosure: Environmentally sealed, NEMA 4/IP65, corrosion resistant cast aluminum
- Weight: 43 lb (19kg) per pad
- Options: NTEP approved version (20,000 x 50 lb capacity per pad)
- Accessories:
 - Universal Battery Charger, 115/230 VAC or 12 VDC power input (charge up to 4 batteries simultaneously from either 115/230 VAC or 12 VDC vehicle power)
 - Replacement 6 volt rechargeable battery
 - Portable aluminum carrying cases (available for 2, 4, and 6 pad systems - contact factory)

Your Performance Guarantee

Load Ranger is backed by MSI's exclusive limited warranty and is guaranteed to perform to your highest expectations. Quality sales and service are provided by MSI's worldwide network of factory-authorized

distributors. Your local distributor can present free product demonstrations and provide answers to your specific weighing application.

If you would like additional information on the MSI-5300 Load Ranger, other

MSI products or to locate the distributor nearest you, please contact MSI at 206-433-0199, toll free at 800-874-4320 (USA and Canada) or visit our website at www.msiscales.com.



Specifications subject to change without notice.
PUB.356-12-07 Printed in U.S.A.
© 2008 by Measurement Systems International, Inc.



Measurement Systems International

14240 Interurban Avenue South STE.200
Seattle, Washington 98168-4661 U.S.A.
Phone: 206-433-0199 • Fax: 206-244-8470
Web: www.msiscales.com • Email: info@msiscales.com

"We weigh quality first"