

**MSI-3700 Magnum Plus Scale**  
(carriage attachment)

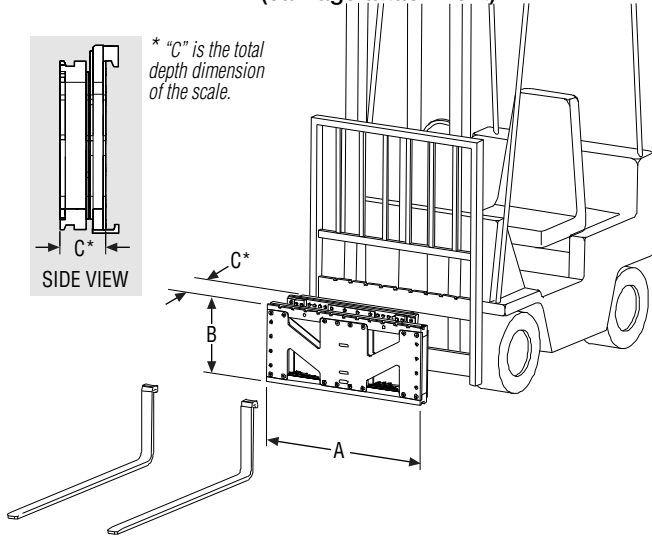

**MSI-3650 Digital Weight Indicator**

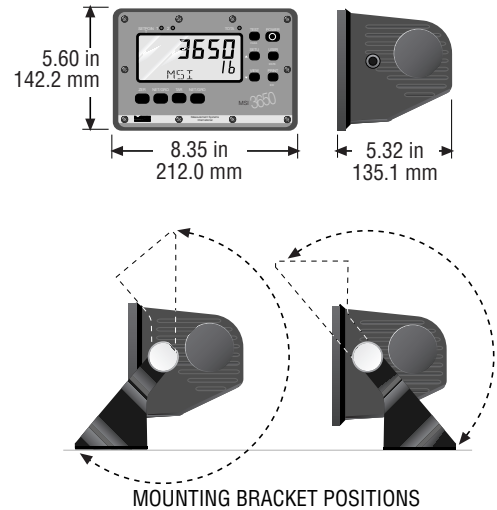

CAPACITY	RESOLUTION	ITA CARRIAGE CLASS	DIMENSIONS (in / mm)			SHIPPING WEIGHT
			A	B	C	
5,000 lb 2,500 kg	2 lb 1 kg	II II	36.0 in 914.4 mm	16.0 in 406.4 mm	4.35 in 110.49 mm	180.5 lb 81.87 kg
8,000 lb 4,000 kg	2 lb 1 kg	III III	42.0 in 1066.8 mm	20.0 in 508.0 mm	5.0 in 127.0 mm	700 lb 318 kg
10,000 lb 5,000 kg	5 lb 2 kg	III III	48.0 in 1219.2 mm	20.0 in 508.0 mm	5.0 in 127.0 mm	950 lb 431 kg

For higher capacity units or bar-mount style trucks, consult factory.

**Standard System Specifications**

**Scale/Carriage Assembly**

- Rated capacity:** See above chart
- Accuracy:** 0.1% of rated capacity
- Safe Overload:** 200%
- Ultimate Overload:** 500%

**Digital Indicator (MSI-3650)**

- Power:** 10 to 56 VDC
- Display:**
  - 6 digit x 0.90 in. (23 mm) high numeric LCD (weight display)
  - 8 digit x 0.45 in. (11 mm) high alphanumeric LCD (message display)
  - 21 segment analog bar graph for level indications with NTEP option
  - LED annunciator for Totalizing and Set Point indication
  - Photocell activated backlighting

**Functions:**

- Power: On/Off
- Zero: zero out residual weight
- Net/Gross: switch between Net (tared) and Gross weight
- Tare: tare out empty container weight and indicate Net weights
- Total: accumulate weighments in register manually or automatically
- ViewΣ: display accumulated weighments in registers
- Print: digital output to external printer
- User: program user defined functions
- Test: display and function test
- Setup: for selection of programming functions and features

**Programmable Features:**

- Auto or Manual Tare entry
- Auto or Manual Totalizing
- 12 programmable ID codes (more with expanded memory option)
- Lock mode for preventing unauthorized program changes
- Pounds / kilograms mode selectable
- Digital calibration

**Enclosure:**

NEMA IV, IP65 alodined and powder coated cast aluminum

**Operating Temperature:**

- 14° to 140°F (-10° to 60°C)

**Product Options:**

- Class III carriage attachment 8,000 lb x 2 lb (4000 kg x 2 kg)
- Class III carriage attachment 10,000 lb x 5 lb (5000 kg x 2 kg)
- NTEP approved for legal for trade installations only available with Class II attachment. Maximum capacity of 5,000 lb x 5 lb (2,500 kg x 2 kg)
- Expanded ID Memory up to 240 ID Codes
- RS232 data output with real time clock and full output formatting
- Tape printer with truck mounting bracket (requires RS232 option)
- Internal battery power supply (2 ea. "D" alkaline batteries)
- Cable retracting and storage assembly kit with 200 inch maximum lift height (contact factory for specifications)
- Substitute standard indicator with MSI-3750 (contact factory for specifications)
- Wireless RF data transfer

**Warranty:** One year



Specifications subject to change without notice.

PUB.123-03-90E Printed in U.S.A.  
© 2004 by Measurement Systems International, Inc.

*"We weigh quality first"*



14240 Interurban Avenue South STE.200  
Seattle, Washington 98168-4661 U.S.A.  
Phone: 206-433-0199 • Fax: 206-244-8470  
Web: www.msiscalcs.com • Email: info@msiscalcs.com