

WEIGH-TRONIX

This low priced WP-234 printer is designed to meet your simple application requirements. It provides a paper copy for weighments or data collection as fast as 130 lines per minute.

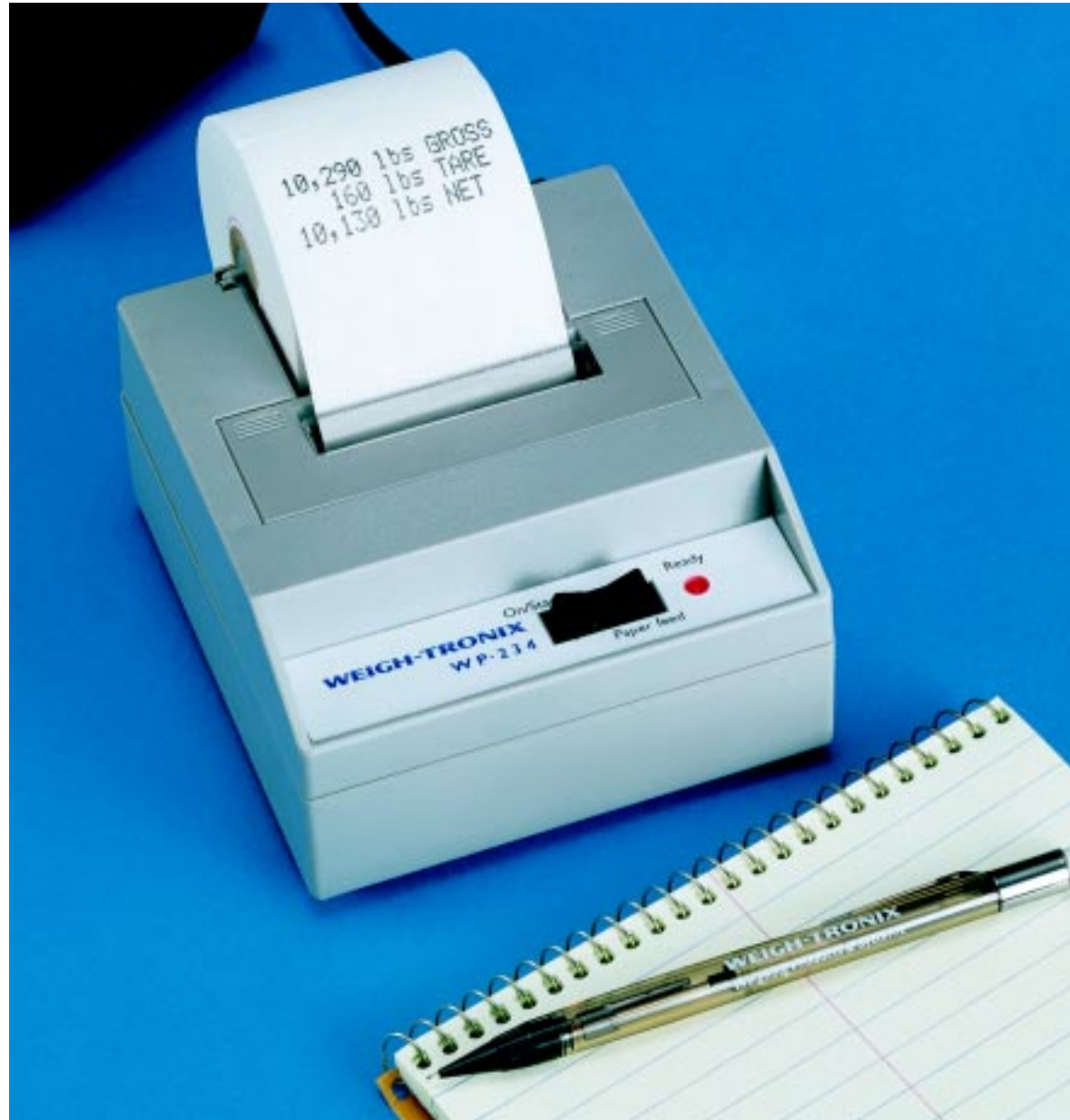

WP-234 Dot Matrix Impact Printer

Features and benefits

- RS-232 serial or 20mA current loop input
- Small enough to fit anywhere—
Table top, wall, or panel mounting available.
- 24-, 32-, and 40-column printing capacity
- Uses standard 2 1/4" adding machine paper and accepts two-part paper
- Programmable double high and/or double wide characters
- Easily replaceable black or purple ink cartridge.
- Dual function rocker switch: On/Standby, Paper feed
- Available in AC or DC models.
- X-ON, X-OFF and Busy Signal-clear to send (CTS) are both supported.
- Selectable sequential transaction number printing

Specifications

Print method: Impact dot matrix

Character matrix: 5 x 8, 5 x 7, or 5 x 5 matrix

Character spacing:

24 column - 12.8 characters/inch

32 column - 17 characters/inch

40 column - 21 characters/inch

Line feed spacing:

7.4 lines per inch...single high character mode

Print speed:

130 lines per minute with 24 column

110 lines per minute with 32 and 40 column

Character buffering: 1.5K

Paper roll:

Table top - 2 1/4" W x 2 3/4" O.D.; 0.44" I.D.

Panel mount - 2 1/4" W x 1 1/4" O.D.

AC voltage:

9 VAC (120 VAC stepdown converter included)

(Multi-national converters optional)

Power: 1.5 Watts (idle) 15 Watts (while printing)

DC voltage:

Optional 9-12 VDC, 140 mA idle, 1.0 A typical, 5.5A peak

Programmable baud rates:

300, 600, 1200, 2400, 4800, 9600, 19200

Character format:

7 or 8 data bits, 1 or 2 stop bits, even, odd or no parity

Environment: 41°F to 104°F (5°C to 40°C)

Shipping weight: 4 lbs

Options: Time/date battery protected circuitry

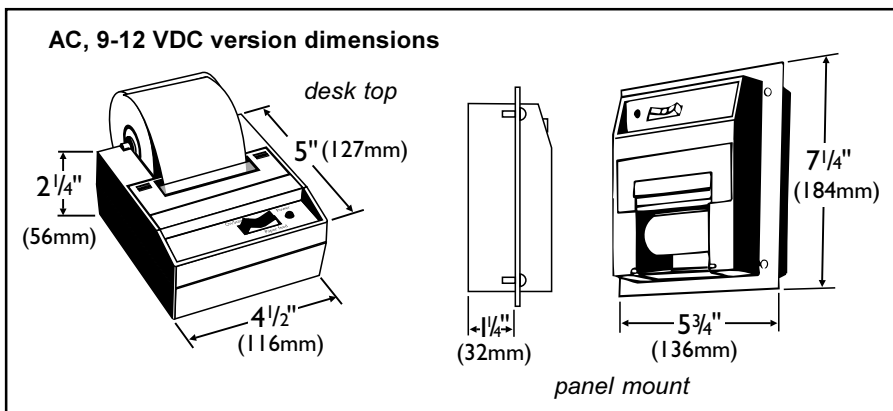

Weigh-Tronix

1000 Armstrong Dr.
Fairmont, MN 56031 USA
Telephone: 507-238-4461
Facsimile: 507-238-4195
e-mail: industrial@weigh-tronix.com
www.wtxweb.com

Weigh-Tronix Canada, ULC

217 Brunswick Blvd.
Pointe Claire, QC H9R 4R7 Canada
Telephone: 514-695-0380
Facsimile: 514-695-6820

WEIGH-TRONIX

Weighing Products & Systems