

# WEIGH-TRONIX



**WP-233 Dot Matrix  
Impact Printer**

## Features and benefits

- RS-232 or 20mA input
- Small enough (4½" x 4" x 2") to fit anywhere—  
Table top, wall, or panel mounting available.
- 24-, 32-, and 40-column printing capacity
- Uses standard 2½" adding machine paper
- Programmable double high and/or double wide characters
- Easily replaceable black or purple ink cartridge.
- Dual function rocker switch: On/Standby, Paper feed
- Available in AC or DC models.
- Optional watertight enclosure available.
- X-ON, X-OFF and Busy Signal-clear to send (CTS) are both supported.
- Selectable sequential transaction number printing

## Specifications

**Print method:** Impact dot matrix

**Character matrix:** 5 x 8 or 5 x 5 matrix

**Character spacing:**

24 column - 12.8 characters/inch

32 column - 17 characters/inch

40 column - 21 characters/inch

**Line feed spacing:**

7.6 lines per inch...single high character mode

**Character buffering:** 9.5K

**Paper roll:**

Table top - 2¼" W x 2½" O.D.; 0.44" I.D.

Panel mount - 2¼" W x 1¼" O.D.

**Power:** 1.5 Watts (idle) 10 Watts (while printing)

**AC voltage:** 9 VAC (120 VAC stepdown converter included)

**DC voltage:**

Optional 9-12 VDC, 100 mA idle, 1.5 A typical, 2.9A peak

Optional 12-48 VDC

**Available baud rates:**

300, 600, 1200, 2400, 4800, 9600, 19200

**Character format:**

7, 8 data bits, 1 or 2 stop bits, even, odd or no parity

**Environment:** 5°C to 40°C (41°F to 104°F)

**Shipping weight:** 3 lbs

**Options:**

Time/date battery protected circuitry

Wall mounting versions and a watertight enclosure are available, for both AC and DC models.

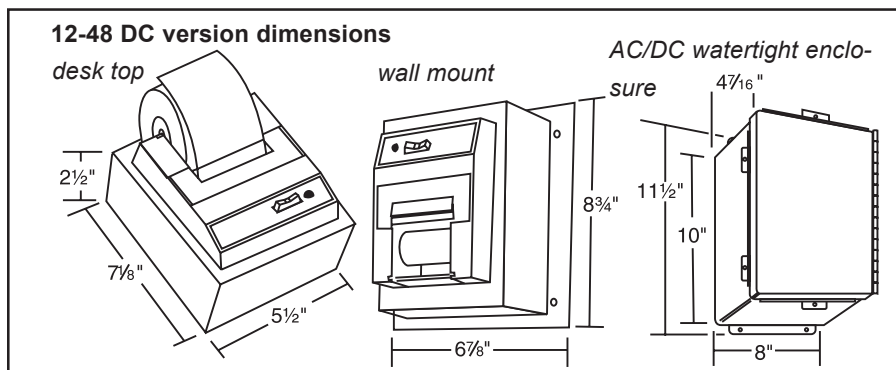
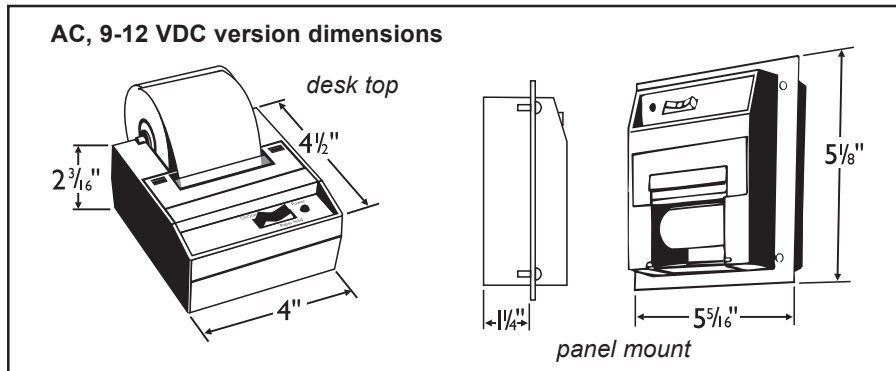

### Weigh-Tronix

1000 Armstrong Dr.  
Fairmont, MN 56031 USA  
Telephone: 507-238-4461  
Facsimile: 507-238-4195  
e-mail: industrial@weigh-tronix.com  
www.wtxweb.com

### Weigh-Tronix Canada, ULC

217 Brunswick Boulevard  
Pointe Claire, QC H9R 4R7 Canada  
Telephone: 514-695-0380  
Toll free: 800-561-9461  
Facsimile: 514-695-6820  
www.weigh-tronix.ca

# WEIGH-TRONIX

Weighing Products & Systems