



WI-125 LED indicator

Technical Specification

DESCRIPTION

General

Enclosed in a stainless steel NEMA 4X case, the WI-125 LED Indicator will serve you effectively in wet or dry environments. And its crisp, easy-reading LED display will speed any weighing process.

- Washdown safe
- Numeric keypad
- Easy operation
- Fast-reading LED display

Features and benefits

Six function keys

No confusing functions. Train operators in minutes.

LED display

Bright, crisp, fast-reading. Speeds weighing process and reduces operator error.

NEMA 4X washdown

Stainless steel enclosure provides corrosion and washdown resistance to rough indoor and outdoor use.

Numeric keypad

Makes tare entry more flexible. Enter known weights from the keypad, or use the TARE key to enter container weights.

RS-232 serial port

Provides link with printers and computers.

Remote key inputs

Logic level inputs for Zero, Print, Tare.

Print formatting

Customize your printout with company name, message, character size and location, etc. right from the front panel.

Heavy-duty swivel mounting stand

Adjust the display quickly to the best sight line.

RFI protection

Provides stable weight readings in environments with moderately high levels of RFI radiation.

Single channel accumulation

Prints each weighment individually, then provides count and total weight.

Options

- Time and date
- 8 Cutoffs (setpoints)
- Analog output (0-5v, 0-10v, 1-5mA, 4-20mA, 10-50mA)



SPECIFICATIONS

Electrical

Power

115 volts AC/230 volts AC, 50/60 Hz single phase

Excitation

10 VDC

Display

Type

Eight .6-inch high LED digits with LED annunciators

Display rate

Configurable to 1, 2, or 5 times per second

Display averaging

One to ten display periods

A to D conversion rate: 60 times per second

Resolution

Internal resolution

884,736 counts at 3 mV/V

294,912 counts at 1 mV/V

Increments

0.0001 to 20,000 programmable to any division size between these limits.

Analog range

-0.14 to +3.5 mV/V

Interface

Controls

GROSS/NET, TARE, ZERO, PRINT, UNITS, MENU, Keypad (0-9)

Annunciators

Gross, net, center of zero, print, lb and kg

Load cells

Drives up to twelve 350-ohm Weigh Bars® or load cells

Agencies

NTEP, CC#92-167A4 Class III/III L

Canadian Weights and Measures, #AM 4868

CSA

FCC Class A

UL/CUL

Environment

-10 to 40° C (14 to 104° F)

10 to 90% relative humidity

Shipping weight

6.5 lb (2.9 kg)

Dimensions

8.25"W x 6.25"H x 4.25"D (without mounting bracket)

10.05"W x 8.89"H x 5.29"D (with mounting bracket)

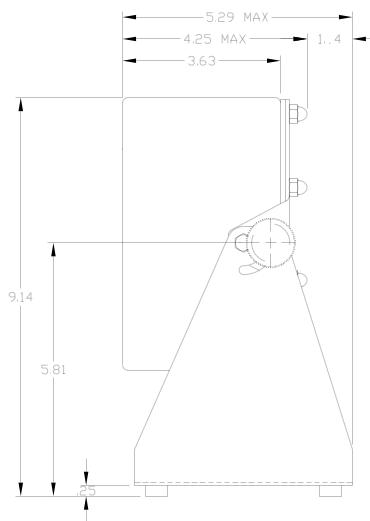
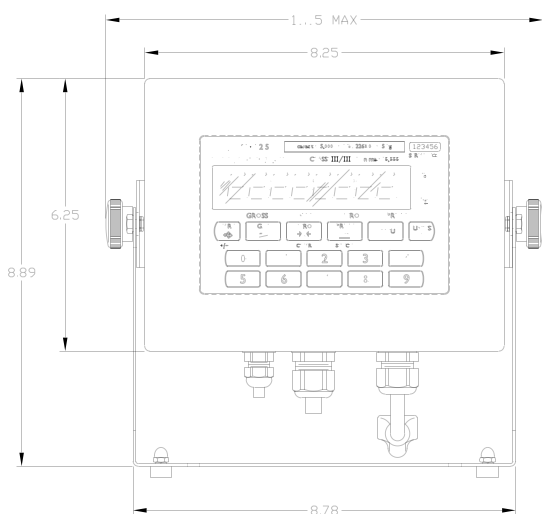

Weigh Bar® is a registered trademark of Avery Weigh-Tronix, LLC.

Avery Weigh-Tronix - USA

1000 Armstrong Drive,
Fairmont, MN 56031-1439 USA
usinfo@awtxglobal.com
Toll-Free: (800) 533-0456
Phone: (507) 238-4461

Avery Weigh-Tronix - UK

Foundry Lane, Smethwick,
West Midlands B66 2LP UK
info@awtxglobal.com
Phone: +44 (0) 8453 66 77 88
Fax: +44 (0) 121 224 8183

Please call us or visit www.averyweigh-tronix.com
for your nearest Avery Weigh-Tronix distributor

Avery Weigh-Tronix

